

2023

时间 Time	课程内容 Content	授课教师 Lecturer	教室 Classroom	授课平台 Meeting ID
August 7 8:00-11:15	Introduction, Course Requirements and Evaluation Approach; Introduction to AI	M. Xia	线上	腾讯会议 689-2968-5886
August 8 8:00-11:15	Types of Learning; Classification; Regression	M. Xia	线上	腾讯会议 689-2968-5886

August 9 8:00-11:15	Improving Predictive Models; Introduction to Deep Learning;	M. Xia	线上	腾讯会议 689-2968-5886
August 10 8:00-11:15	Lab practice	M. Xia	线上	腾讯会议 689-2968-5886
August 11 8:00-11:15	Convolutional Neural Networks, Recurrent Neural Networks	M. Xia	线上	腾讯会议 689-2968-5886
August 12 8:00-11:15	Deep Generative Models; Reinforcement Learning	M. Xia	线上	腾讯会议 689-2968-5886
August 13 8:00-11:15	Application of AI in Smart Engineering	M. Xia	线上	腾讯会议 689-2968-5886
August 14 8:00-11:15	Final Project Presentation	M. Xia	线上	腾讯会议 689-2968-5886

M X a

2017

2012

2009

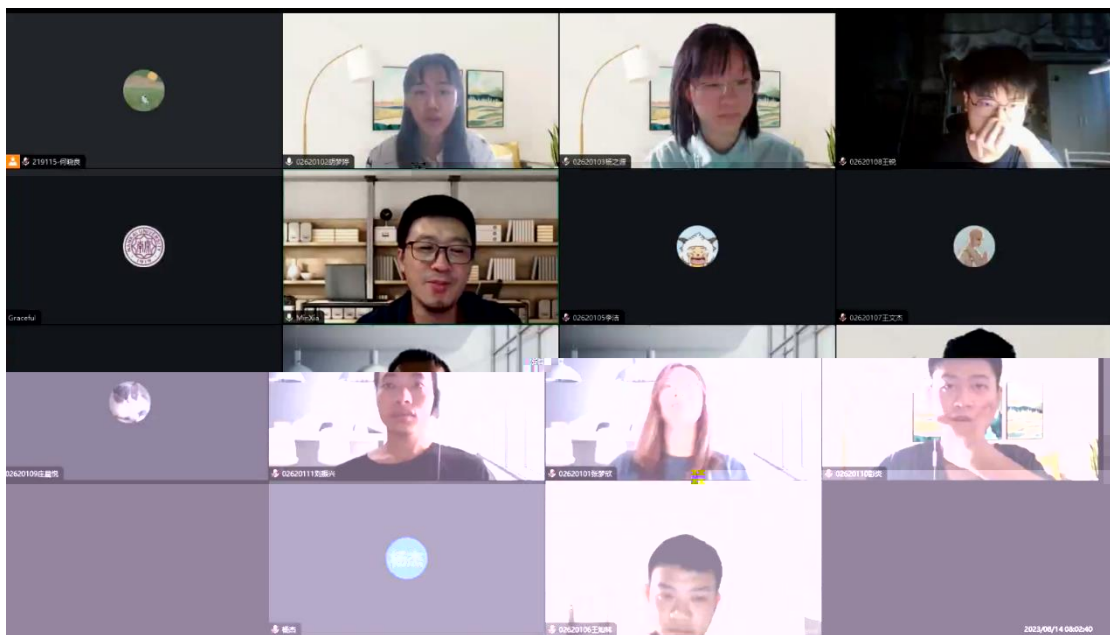

Long Short Term Memory (LSTMs)

How do LSTMs work?

- 1) Forget 2) Store 3) Update 4) Output

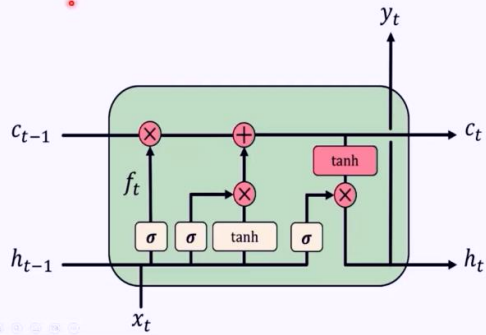

:(1)

; (2)

; (3)

MATLAB

(ADAS)

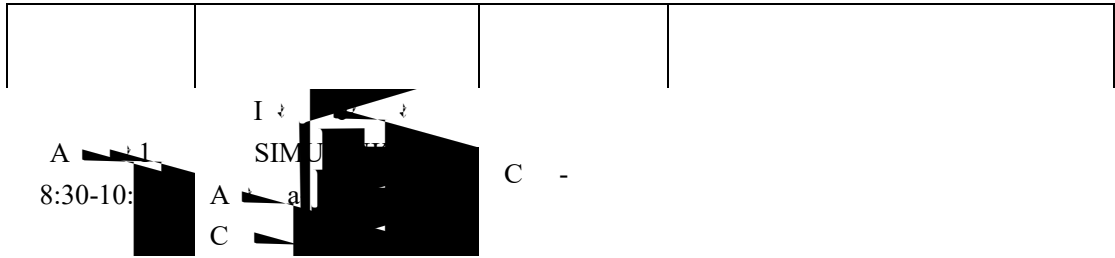



Chin-an Tan

Ta C -A (U Ca a a²
B) (Ca a
I T c)

NVH :

;
(ASME) ; ASME ASME
(G a M)

R a c Lab a²)



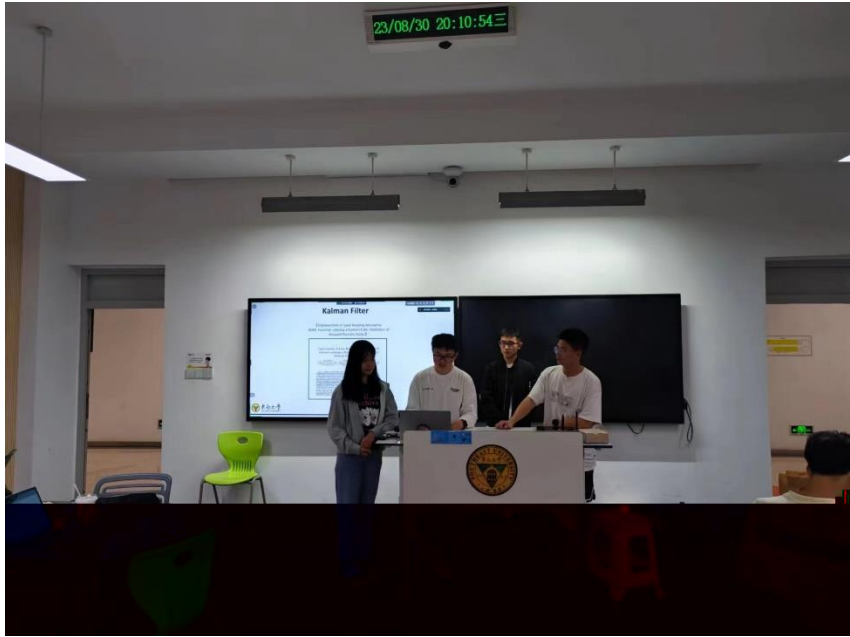

AM 3D

AM

AM

AM

T	C	L c	C a	M ID
A 21 8:00-9:	I Ma T c 3D a , c a	WC		#V V M : 955-4962- 9485
A 22 8:00-9:	T a c a a ; a a a	WC		#V V M : 955-4962- 9485
A 23 14:00-15:	E b a b	WC		#V V M : 955-4962- 9485
A 24 8:00-9:	C a c	WC		#V V M : 955-4962- 9485
A 25 8:00-9:	A ca a 3D b ca , a	WC		#V V M : 955-4962- 9485
A 26 8:00-9:	a a a a a	WC		#V V M : 955-4962- 9485
A 27 14:00-15:	R a a a a	WC		#V V M : 955-4962- 9485

A 28 8:00-9:00	S a a .	W C		#V V M : 955-4962- 9485
A 29 8:00-9:00	La a a	GF S	J1-205	
A 30 8:00-9:00	S a a a a c a	GF S	E T a C 119	
A 31 14:00-15:00	S a a a a a c	GF S	E T a C 119	
S b 1 14:00-15:35	S a a a c	GF S	E T a C 119	
S b 4 15:50-17:25	La a a	GF S	J1-205	
S b 5 8:00-9:35	S a a .	GF S	J1-205	
S b 6 8:00-9:35	S a a .	GF S	J1-105	
S b 7 8:00-9:35	S a a .	GF S	J1-105	

2018
National Natural Science Foundation of China
Academy of Mathematics and Systems Science
60



2009

2007

2008

2010

W
80 SCI
2020

1

2

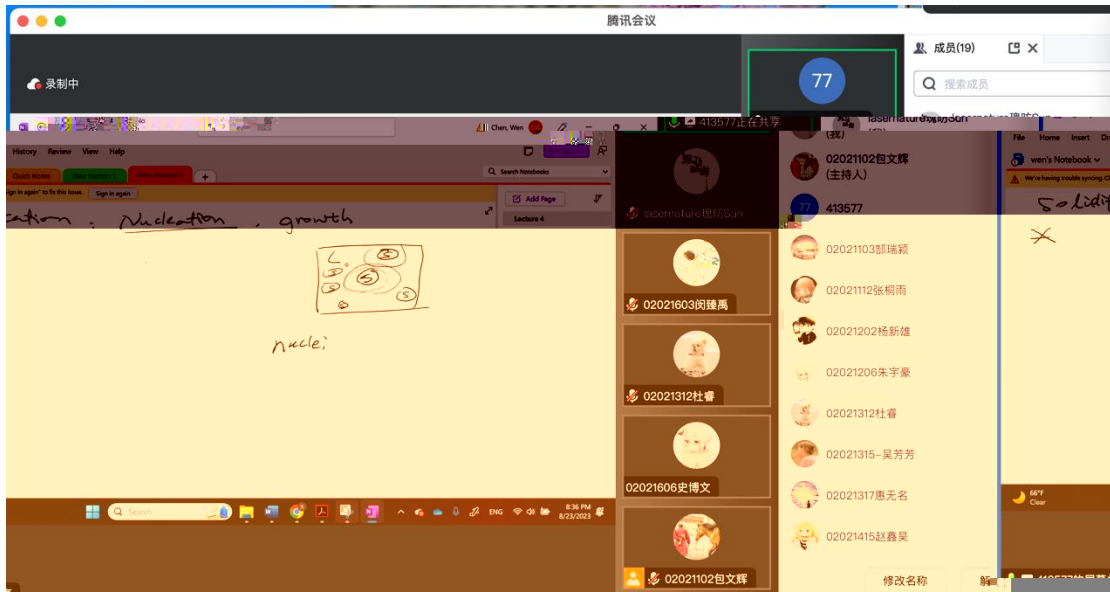

Thermal residual stresses

State of Stress: Heating

Thermal Deformation from Heat Input

Interface with Substrate

State of Stress: Cooling

Thermal Deformation from Cooling

Interface with Substrate

Strategy:

1. Scan pattern (chessboard)
2. Preheat substrate
3. Post-processing (medium temperature treatment)

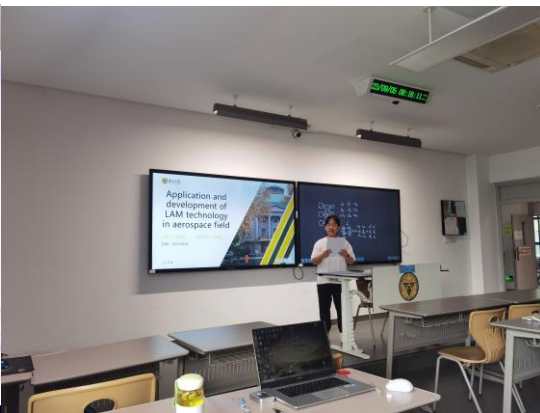
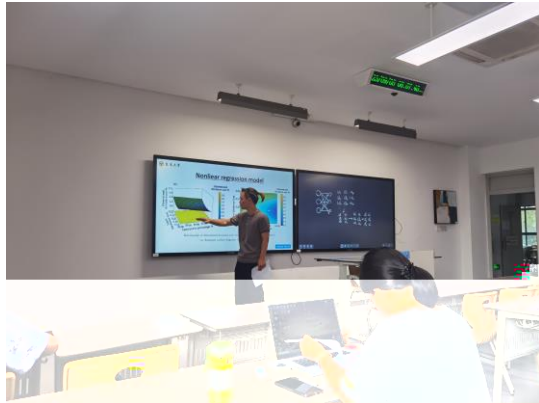

--	--	--	--

2023-8-21 18:30-20:00



W

W

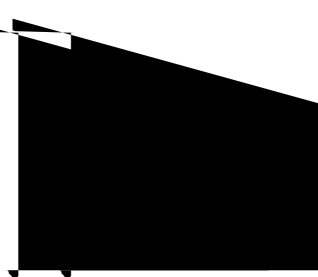

;



A B z

A B z

,

TGGS

IKT

A B z

(

,

TGGS

)

A

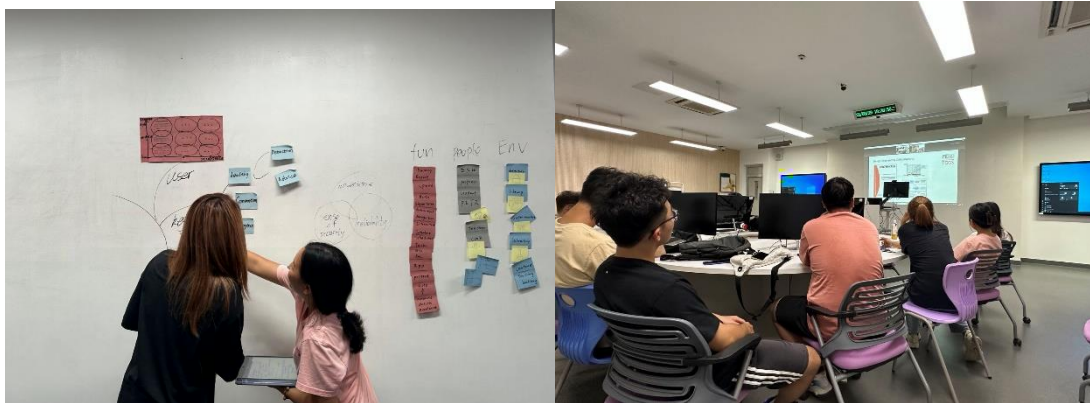
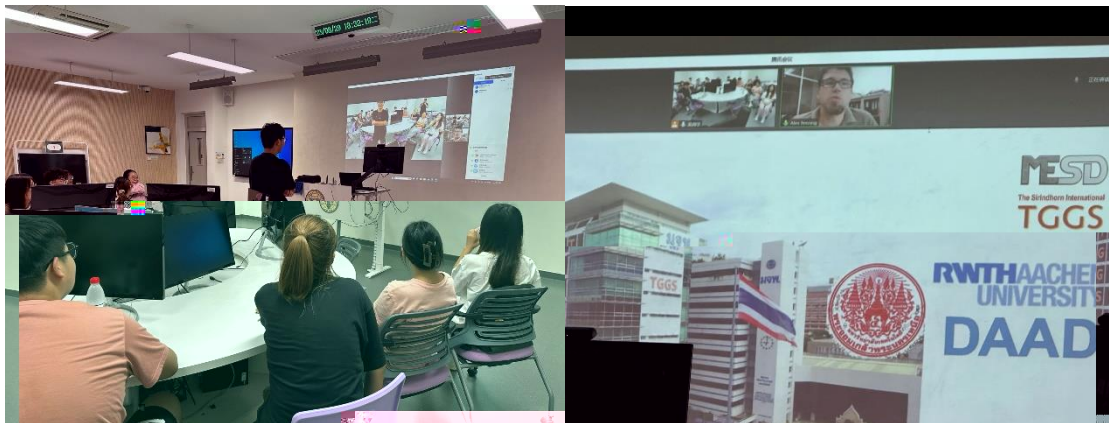

1

2

3 Ma ab/S

4

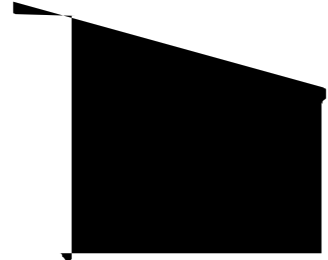

T	C	L c	C a	M ID
A 14 20:30-22	I	Y a Z a	J1-502	#V VM :
A 16 20:30-22	HEV C	Y a Z a	J1-502	#V VM :
A 18 9:30-12	T a Ma ab/S	Y a Z a	J1-502	#V VM :
A 21 20:30-22	C HEV P a	Y a Z a	J1-502	#V VM :
A 23 20:30-22	D c HEV	Y a Z a	J1-502	#V VM :
A 28 20:30-22				

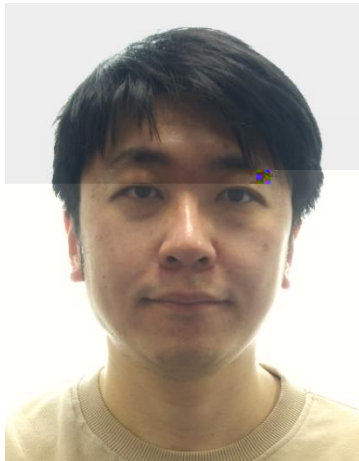

Y a Z a

2018

2018

200

2021 6

/

100

IEEE

ASME

IF>10 /

60

25

1285

21

IEEE ITSC

CVCI

FISITA

/

PPT



2023

5

85

1

2

3

4

- -

,

5

6

5

1

5

5

4.1

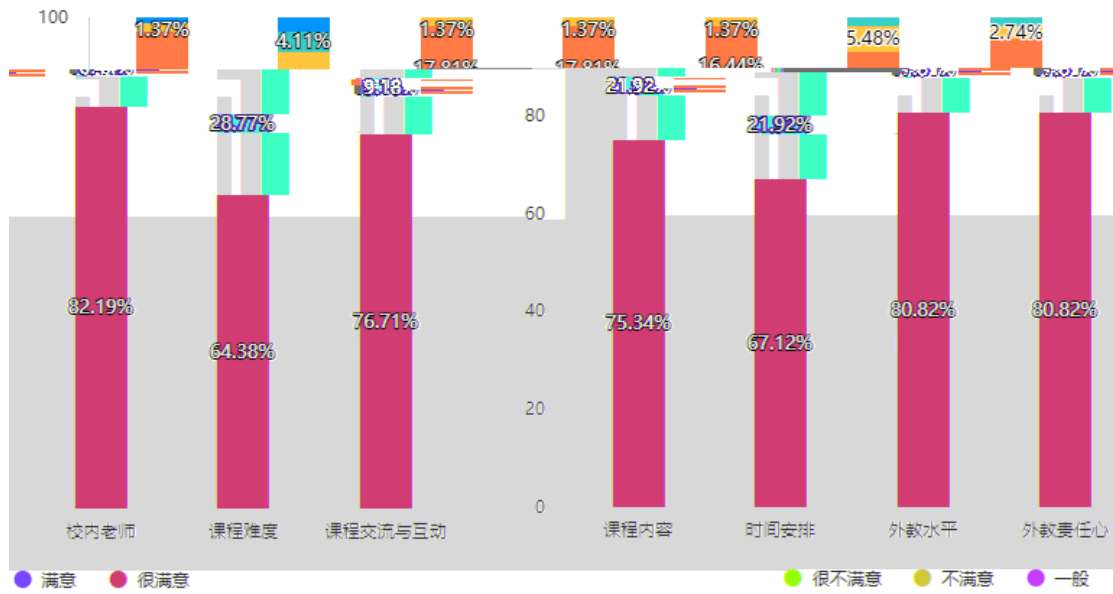

4.2



1	02620101		
2	02620102		
3	02620103		
4	02620104		
5	02620105		
6	02620106		
7	02620107		
8	02620108		
9	02620109		
10	02620110		
11	02620111		

1	02021117		
2	02021502		
3	02021511		
4	02021209		
5	02021503		
6	02021217		
7	02021423		
8	02021402		
9	02021110		
10	02021122		
11	02021120		
12	02021114		
13	02021118		
14	02021116		
15	02021113		
16	02021115		
17	02021104		
18	02021416		
19	02021513		
20	02021517		

1	02021106		
2	02021111		
3	02021212		
4	02021214		
5	02021222		
6	02021301		
7	02021303		
8	02021308		
9	02021314		
10	02021316		
11	02021319		
12	02021320		
13	02021321		
14	02021403		
15	02021406		
16	02021412		
17	02021521		
18	02021522		
19	02021601		
20	02021614		
21	61520521		